



Fédération Internationale des Lutttes Associées
International Federation Of Associated Wrestling Styles

Avenue Juste Olivier
CH-1006 Lausanne (Suisse)
Tel. : (41 21) 312 84 26
Fax : (41 21) 323 60 73

Internet : <http://www.fila-wrestling.com>
e-mail : fila@fila-wrestling.com

WELCOME IN THE NEW WORLD OF WRESTLING

INTERNATIONAL FEDERATION OF ASSOCIATED WRESTLING STYLES

INTERNATIONAL WRESTLING RULES

GRECO-ROMAN WRESTLING

FREE STYLE WRESTLING

WOMEN'S WRESTLING

BEACH WRESTLING

LAUSANNE, 01.03.2005 Edition corrected of the printing's errors after the training of Rome

FOREWORD

Wrestling, like all other sports, obeys Rules which constitute the "Rules of the Game" and define its practice, the aim of which is to "pin" the opponent or to win on points. These regulations apply to all the styles recognised by modern wrestling controlled by the FILA.

The Greco-Roman Style and the Free Style basically differ as follows:

In Greco-Roman Wrestling, it is strictly forbidden to grasp the opponent below the belt line, or to trip him or to use the legs actively to perform any action.

In Free Style wrestling, however, it is permissible to grasp the legs of the opponent, to trip him and to use the legs actively to perform any action.

Double Nelsons are strictly forbidden in women's wrestling.

Beach wrestling is dealt with by a specific rule.

Traditional wrestling, as practised world wide, are subject to specific rules.

Frequently modified and always subject to further modification, the Rules set forth herein must be known and accepted by all wrestlers, coaches, referees and leaders. They call upon those who practise the sport to fight totally and universally, with complete honesty and fair play for the pleasure of the spectators.

FILA

INTERNATIONAL FEDERATION OF ASSOCIATED WRESTLING STYLES

INTERNATIONAL WRESTLING RULES

GRECO-ROMAN WRESTLING - FREE STYLE WRESTLING - WOMEN'S WRESTLING

INDEX

<u>GENERAL RULES</u>	6
Article 1 Object.....	6
Article 2 Interpretation	6
Article 3 Application.....	7
<u>Chapter 1 - COMPETITIONS AND PROGRAMMES</u>	8
Article 4 Competition method	8
Article 5 Competition programme.....	10
<u>CHAPTER 2 - MATERIAL STRUCTURE</u>	12
Article 6 Age and weight categories - competitions.....	12
Article 7 Competitor's licence	14
Article 8 Dress.....	14
Article 9 The mat.....	16
Article 10 Medical service	17
Article 11 Medical service involvement	17
Article 12 Doping.....	18
<u>CHAPTER 3 - OFFICIALS</u>	20
Article 13 Composition	20
Article 14 General duties.....	20
Article 15 The referee.....	21
Article 16 The judge	23
Article 17 The mat chairman	24
Article 18 The Person responsible for refereeing	24
Article 19 Decision and vote.....	24
Article 20 Decision table.....	25

Article 21	Penalties against the officials	26
Article 22	Dress.....	26
<u>CHAPTER 4 - COMPETITION PROCEDURE</u>		27
Article 23	Weigh-in	27
Article 24	Drawing of lots	27
Article 25	Initial classification list	28
Article 26	Pairing off	28
Article 27	Elimination from the competition	28
Article 28	Awards ceremony.....	29
Article 29	Classification by team during individual competitions.....	29
Article 30	Classification during team competitions	29
<u>CHAPTER 5 - THE BOUT</u>		31
Article 31	Duration of the bouts	31
Article 32	Call	31
Article 33	Presentation of wrestlers	31
Article 34	Start.....	31
Article 35	Interrupting the bout	32
Article 36	End of the bout.....	32
Article 37	Stopping and continuing the bout.....	33
Article 38	Types of victories	33
Article 39	Extra time	34
Article 40	The coach	34
<u>CHAPTER 6 - POINTS FOR ACTIONS AND HOLDS</u>		35
Article 41	Evaluation of the importance of the action or hold	35
Article 42	Danger position	36
Article 43	Recording the points	36
Article 44	Grande amplitude holds	37
Article 45	Value assigned to actions and holds	37
<u>CHAPTER 7 - CLASSIFICATION POINTS AWARDED AFTER A BOUT</u>		39
Article 46	Classification points.....	39
Article 47	The fall	40
Article 48	Technical superiority	40
<u>CHAPTER 8 - NEGATIVE WRESTLING</u>		41
Article 49	Parterre position during the bout.	41
Article 50	Red zone.....	41

Article 51	Clinch	42
<u>CHAPTER 9 - PROHIBITION AND ILLEGAL HOLDS</u>		43
Article 52	General prohibitions	44
Article 53	Fleeing the hold.....	45
Article 54	Fleeing the mat	46
Article 55	Illegal holds	46
Article 56	Prohibited holds for schoolboy and cadet categories	47
Article 57	Special prohibitions	48
Article 58	Consequences affecting the bout.....	47
<u>CHAPTER 10 - THE PROTEST</u>		48
Article 59	The protest	48
<u>Chapter 11 - INTERNATIONAL RULES SPECIFIC TO WOMEN'S WRESTLING</u>		49
Article 60	Age categories and weight categories.....	49
Article 61	Dress.....	49
Article 62	Weigh-in	50
Article 63	Length of the bout	50
Article 64	General technical rules.....	50
Article 65	Illegal holds	50
<u>CHAPTER 12 - INTERPRETATION OF WRESTLING RULES</u>		52
Article 66	Modifications and unforeseen events	52
<u>CHAPTER 13 - BEACH OF WRESTLING RULES</u>		53
<u>APPENDIX 1 - BASIC VOCABULARY</u>		55

INTERNATIONAL FEDERATION OF ASSOCIATED WRESTLING STYLES

INTERNATIONAL WRESTLING RULES

GRECO-ROMAN WRESTLING - FREE STYLE WRESTLING - WOMEN'S WRESTLING

GENERAL RULES

Article 1 Object

The article is drawn up to implement the provisions of the following FILA Statutes:

- Financial Regulations
- Disciplinary Regulations
- Regulations governing the organisation of international contests
- All the specific Regulations

The International Rules of Wrestling have, as their specific objectives, to:

- define and specify the practical and technical conditions under which bouts are to take place
- determine the value to be assigned to wrestling actions and holds
- list situations and prohibitions
- determine the technical functions of the officials
- determine the competition system, methods of classification, penalty, elimination of competitors, etc.

Being subject to modification in light of practical observations as to their application and research into their effectiveness, the international Rules set forth in the following document constitute the framework within which the sport of wrestling is conducted in all its styles. Traditional wrestling is governed by rules specific to the various styles.

Article Interpretation

In the event of disagreement as to the interpretation of the provisions of any article in the following Rules, the Executive Bureau of FILA is solely empowered to determine the exact meaning of the article(s) in question. Only the French text shall be held as true.

Article 3 Application

Application of these Rules to the Olympic Games, to Championships and to all international meets under the control of FILA is compulsory.

During international tournaments, a competition procedure that differs from that set out in the Rules may exceptionally be used, provided that permission has been granted by FILA and all participating countries.

CHAPTER 1 - COMPETITIONS AND PROGRAMMES

Article 4 Competition method

Competition System and Method

The competitions take place by direct elimination system with :

- Pairing in the order of the numbers drawn at random.
All competition conditions take place by direct elimination system with repêchage for the losers against the opponents competing for the first and second places match. The ideal number is searched at the beginning of the competition and the matches will take place from the bottom of the draw.
- All the wrestlers losing only against the two finalists will make up a repêchage. The repêchage matches begin with wrestlers who lost in the first round (including in matches to obtain the ideal number) against one of the two finalists up to the losers in the semi-finals by direct elimination. The winners of the two repêchage matches will receive each the bronze medal.
- Each weight category begins and ends in a day. Each category weigh-in takes place the day before the beginning of the category concerned.

The competition takes place in the following manner:

- qualification round
- elimination round
- repêchage round
- finals

If there are less than 6 wrestlers in a weigh-in category, the Nordic round will take place (each wrestler against each wrestler).

To apply the direct elimination system, it is necessary to have an ideal number of wrestlers, i.e. 4, 8, 16, 32, 64, etc. If there is no ideal number of wrestlers in a category, qualification matches will take place.

Example of a competition by direct elimination

Let us take the example of a competition with 22 wrestlers in a weight category. The 22 wrestlers draw a number at random from 1 to 22 (draw, annex 1).

Qualification rounds

In order to obtain the closest lower ideal number to apply the direct elimination system (16 wrestlers), qualification matches must take place.

In our example, we have 6 wrestlers with the ideal number of 16. The qualification matches will be disputed by 6 wrestlers who drew the highest numbers after 16, i.e. 17, 18, 19, 20, 21 and 22 and by 6 wrestlers drawing the numbers at random directly before 17, i.e. 16, 15, 14, 13, 12, 11. According to the pairing principle in the order of the numbers drawn at random, the matches take place in the following manner :

- Number 11 against number 12
- Number 13 against number 14
- Number 15 against number 16
- Number 17 against number 18
- Number 19 against number 20
- Number 21 against number 22

The winners of these 6 qualification matches are qualified for the elimination round by direct elimination.

Elimination round

We have the ideal number of 16 wrestlers after the qualification matches. The 16 wrestlers competing for the elimination round are the 10 wrestlers who drew the numbers from 1 to 10 and the 6 wrestlers who won the qualification matches, i.e. numbers 12, 13, 15, 17, 19 and 22 to arrive at (6). According to the pairing principle in the order of the numbers drawn at random, the first elimination round takes place in the following manner :

- Number 1 against number 2
- Number 3 against number 4
- Number 5 against number 6
- Number 7 against number 8
- Number 9 against number 10
- Number 12 against number 13 winners of the qualification matches
- Number 15 against number 17 winners of the qualification matches
- Number 19 against number 22 winners of the qualification matches

Repêchage matches

As mentioned above, all the wrestlers losing against the two finalists will make up a repêchage.

The wrestlers losing against the finalist no 5 are as follows :

- Number 6 (1st round loser)
- Number 7 (2nd round loser)
- Number 3 (3rd round loser)

The wrestlers losing against the finalist no 15 are :

- Number 16 (qualification round loser)
- Number 17 (1st round loser)
- Number 19 (2nd round loser)
- Number 12 (3rd round loser)

The repêchage phase begins with the wrestlers who lost against the finalists at the lowest level of competition.

1st match : no 6 (1st round loser) against no 7 (2nd round loser)

2nd match : 1st match winner (N6) against no 3 (3rd round loser)

The wrestler 6 is the winner in the repêchage group who lost against the no 5 finalist.
The same system applies to the wrestlers losing against the no 15 finalist.

1st match : no 16 (qualification round loser) against no 17 (1st round loser)

2nd match : the winner of the 1st match (N16) against no 19 (2nd round loser)

3rd match : 2nd match winner (N16) against no 12 (3rd round loser)

The no 16 wrestler is the winner of the repêchage group who lost against the no 15 finalist.

The two winners in the two last repêchage matches (N6 and N16) receive each the bronze medal.

FINAL

The two finalists in the elimination rounds, i.e. no 5 and 15, take part in the match for the 1st and 2 places (gold medal).

Classification criteria

The wrestlers of each category will be ranked in the following manner :

- The losers in the two bronze medals finals will be ranked 5th ex aequo
- The ranking points determine the place to rank the wrestlers from the 7th place. In case of a ranking tie, they will be ranked by analysing the following criteria successively.
- If the place of the wrestlers cannot be determined, they will be ranked ex aequo.
 - 1) The most victories by "Fall"
 - 2) The most match wins by superiority
 - 3) The most period wins by superiority
 - 4) The most technical points scored in all the competition
 - 5) The fewest technical points received in all the competition

The wrestlers taking part in the repêchage phase will also be ranked according to the ranking points earned during the competition.

NB. Disqualified wrestlers for brutality or unfair behaviour will be eliminated and not ranked in this situation. The wrestler progressing in the repêchage phase will compete directly against the following wrestler.

- If a wrestler does not present himself to the mat for whatever reason as soon as the competition has started, his opponent(s) win the match.

Articles 5 Competition programme

The duration of Olympic Games, Senior and Junior World Championships is fixed as follows :

6 days for three styles (L/F, G/R, L/L) and three mats. However depending on the number of entries received, one mat can be added or withdrawn for all competition types with FILA's agreement.

In principle, for all competition types, the matches shall not last longer than three hours. For all competition types, a weight category begins and ends after maximum one day.

For each competition round a weight category must in principle take place on the same mat and not on several mats at the same time. All the matches for the 1st, 2nd and 3rd places must take place on one mat.

CHAPTER 2 - MATERIAL STRUCTURE

Article 6 Age and weight categories - competitions

a) Age categories

The age categories are as follows:

Schoolboys	14-15 years (from 13 with medical and parental certificate)
Cadets	16-17 years (from 15 with medical and parental certificate)
Juniors	18-20 years (from 17 with medical and parental certificate)
Seniors	20 years and older

Wrestlers in the junior age category are allowed to participate in the competitions for seniors. However, wrestlers aged 18 in the year concerned must provide a medical certificate and parental authorisation. Wrestlers aged 17 in the year in question may not participate in senior competitions.

Age will be verified at all Championships and competitions during the final registration, six hours before the weigh-in.

To do so, the head of each delegation shall submit the following documents to the FILA technical delegate:

- the wrestler's licence with the stamp for the current year
- the wrestler's individual passport or identity card (group passports are not accepted)
- an honour certificate for each participant issued by the President of the National Federation attesting to the age of the wrestler; this certificate must be drawn up in accordance with the model supplied by FILA, on the National Federation's letterhead.
- a wrestler may participate in a competition only under the nationality appearing on his passport. If, at any time, it is determined by FILA that the statement was false and that fraud occurred, the disciplinary measures provided for to this end will be immediately applied against the Federation, the wrestler and the person whose signature appears on the fraudulent certificate.
- each wrestler who participates in a competition automatically agrees to FILA to use his filmed or photographed image for the promotion of the competition or of competitions to come. If a wrestler refuses to agree to these conditions, he will have to make this clear at the entry stage and, may therefore be excluded from the competition.

b) Weight categories

The weight categories are as follows:

SCHOOLBOYS	CADETS	JUNIORS	SENIORS
1. 29-32 kg	1. 39-42 kg	1. 46-50 kg	1. 50-55 kg
2. 35 kg	2. 46 kg	2. 55 kg	2. 60 kg
3. 38 kg	3. 50 kg	3. 60 kg	3. 66 kg
4. 42 kg	4. 54 kg	4. 66 kg	4. 74 kg
5. 47 kg	5. 58 kg	5. 74 kg	5. 84 kg
6. 53 kg	6. 63 kg	6. 84 kg	6. 96 kg
7. 59 kg	7. 69 kg	7. 96 kg	7. 96-120 kg
8. 66 kg	8. 76 kg	8. 96-120 kg	
9. 73 kg	9. 85 kg		
10. 73-85 kg	10. 85-100 kg		

Each contestant deemed to be taking part of his own free will, and responsible for himself, shall be allowed to compete in only one weight category: the one corresponding to his weight at the time of the official weigh-in.

For categories in the senior age group, competitors may opt for the next higher category than their body weight, except for the heavy weight category, for which contestants must weigh over 96kg.

c) Competitions

International competitions for the various age categories are as follows:

Schoolboys 14-15 years	international competitions (bilateral and regional)
Cadets 16-17 years	International competitions Continental Championships each year
Juniors 18-20 years	international competitions Continental Championships each year World Championships each year
Seniors 20 years and older	international competitions Continental Championships each year

	Continental Cups each year
	World Championships each year (apart from Olympic Games years)
	World Cup each year
	Challenge matches
	Masters
	International Grand Prix
	FILA Grand Prix Galas
	Super Star matches
	Olympic Games every four years
Veterans 35 years and older	competitions according to the programme, specific categories and Regulations

Article 7 Competitor's licence

Any male or female school aged, cadet, junior, or senior wrestler who competes in the Olympic Games, World Championships, World Cups, Continental Championships, Cups and Games, Regional Games and the World and Continental League must hold an international competitor's licence, as defined by special Regulations.

The competitor must, at the time of the weigh-in, present his licence to the official delegate who, in turn shall submit it for verification to the FILA representative. The latter shall return it on the same day to the team manager of the said competitor.

The licence is valid only when it bears the FILA stamp for the current year.

By paying for the stamp, the wrestler (apart from Veterans) is insured for medical and hospital costs in the event of an accident arising during the competition in which he is participating during the following events only: Olympic Games, World Championships, Continental Championships, World Cups and World League only.

The licence and the stamp are compulsory for all senior international games organised by FILA.

Article 8 Dress

At the beginning of each day, each competitor must be closely shaven or have a beard of several months' growth.

k) The competition singlet

Contestants must appear on the edge of the mat wearing a FILA approved one-piece singlet of the colour assigned to them (red or blue). It is forbidden to have a mixture of red and blue colours on the singlet.

The wrestler must wear:

- his country's emblem on his chest

- the abbreviation of his country's name - maximum size 10cm x 10cm on the back of his singlet

The wrestler must not:

- wear the emblem or abbreviation of another country
- The use of light knee pads containing no metal parts is allowed.
- The wrestler must have a cloth handkerchief with him during the whole of the match.

l) Advertising on clothing

Apart from during the Olympic Games where the IOC Rules apply, competitors can wear a sponsor's name on their thigh or on their lower back. Contestants may also wear their sponsors' names on the back or sleeves of their robes. Lettering and symbols may not be higher than 6 cm to identify the sponsor.

m) Ear protectors

For those wrestlers who wish to wear ear protectors, they must be approved by FILA and must not contain any metal or have hard shells.

The referee can oblige a wrestler whose hair is too long to wear ear protectors.

n) Shoes

Contestants must wear wrestling shoes providing firm support for the ankles. The use of shoes with heels or nailed soles, shoes with buckles or with any metallic part, is prohibited. Shoes may be without laces. Shoes with laces should be wrapped with sticky tape so that they do not come undone during the match. Each competitor is responsible for providing the tape himself for the shoes which will be controlled before getting on to the mat.

o) Bans

It is prohibited to:

- wear bandages on wrists, arms or ankles except in the case of injury and on doctor's orders. These bandages must be covered with elastic straps.
- apply any greasy or sticky substance to the body
- arrive at the mat perspiring for the beginning of the match as well as at the beginning of each period.
- wear any object that might cause injury to the opponent, such as rings, bracelets, prosthesis, etc.

At the weigh-in, the wrestler must check that each competitor satisfies the requirements of this article. The wrestler must be warned at the weigh-in that, if his appearance is not correct, he will not be allowed to enter the competition. If the wrestler enters the mat with a non-compliant appearance, officials will allow maximum one minute in order for him to comply. If, after this time, the wrestler is still at fault, he will lose the match by abandon.

Article 9 The mat

A FILA approved mat, with a nine metre diameter and surrounded by a 1.50m border of the same thickness, is obligatory in the following contests: Olympic Games, Championships, Cups and all international competitions.

For the Olympic Games and World Championships, warm up and training mats must also be approved by FILA and be of the same quality as the competition mats.

A red band of one metre wide and forming an integral part of the wrestling area is drawn along the circumference on the inside of the circle of nine metres in diameter.

The following terms will be used to designate the various parts of the mat:

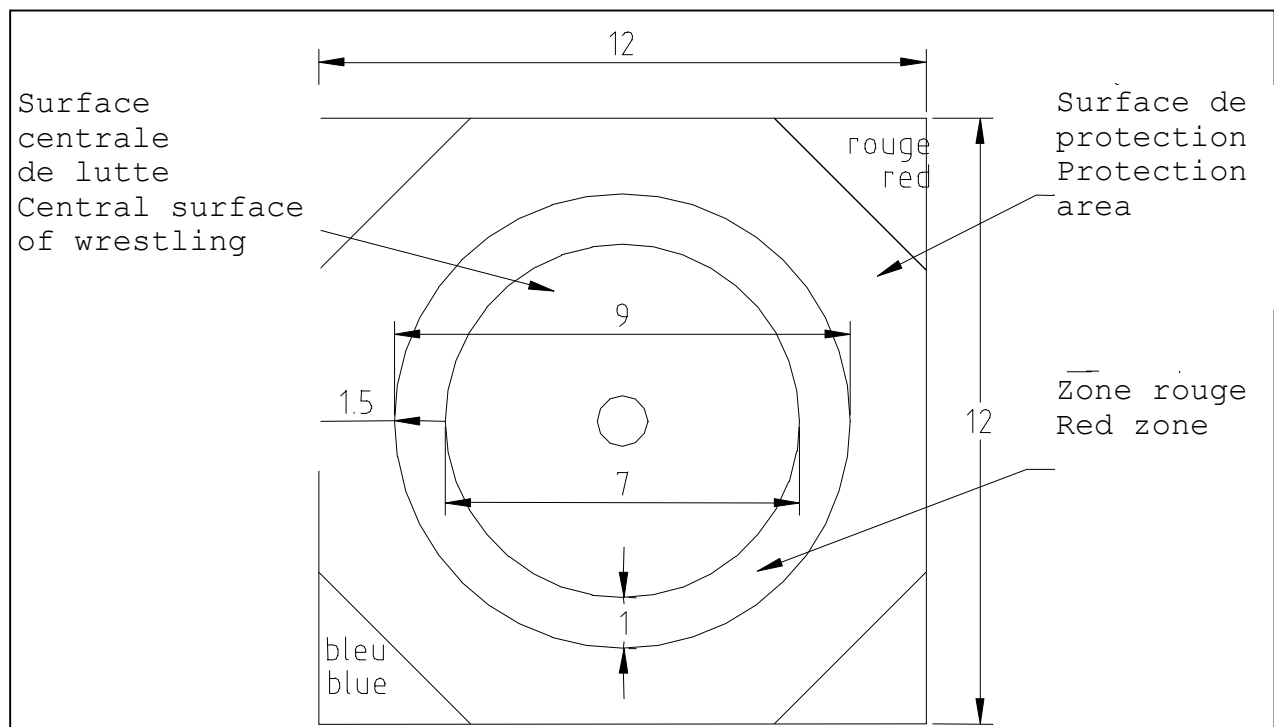

To prevent contamination, the mat must be washed and disinfected before every wrestling session to avoid contamination. When mats that have a smooth, uniform and non-abrasive surface are used (canvas included), the same hygienic measures must also be applied.

A circle must be traced in the middle of the mat with an inside diameter of one metre and a surrounding band 100 cm wide. The colour of the line just described and that of the line marking off the wrestling area must be red.

The diagonally opposite corners of the mat are marked out in the wrestlers' colours ie: red and blue.

The mat should be installed so that it is surrounded by a wide, open space, in order to ensure that the competition proceeds normally.

Article 10 Medical service

As specified in the Regulations defining the international competitor's licence, each wrestler must undergo a medical examination in his own country three days before leaving for Championships, Cups and Games.

The organiser of the competition in question is obliged to provide a medical service responsible for conducting medical examinations prior to the weigh-in and give medical control during the bouts.

The medical service, which is required to operate throughout the competition, is under the authority of the FILA doctor in charge.

Before the competitors weigh in, the doctors shall examine the athletes and evaluate their state of health. If a competitor is considered to be in poor health or in a condition that is dangerous to himself or to his opponent, he shall be excluded from participating in the competition.

Throughout the competitions, and at any time, the medical service must be prepared to intervene in case of an accident. and to decide whether a wrestler is fit to continue the contest.

Doctors from the participating teams are fully authorised to treat their injured wrestlers, but only the coach or a team officer may be present while treatment is being administered by the doctor.

Article 11 Medical service involvement

The FILA doctor in charge has the right and duty to stop a bout at any time through the mat chairman, whenever he considers that either competitor is in danger. He may also stop a bout immediately by declaring one of the wrestlers unfit to continue. The wrestler must never leave the mat, except in the event of a serious injury requiring his immediate removal.

In the event of a wrestler being injured, the referee must immediately ask the doctor to intervene and must ask him if the stoppage is justified or not. If the doctor signals that the stoppage is intentional, the referee will ask the judge or the mat chairman to impose a sanction.

If a wrestler has a visible injury or is bleeding, the doctor will have the time necessary to treat the injury and he decides if the wrestler can carry on the match or not. There is no time limit.

In the case of any medical dispute, the doctor for the team of the wrestler in question has the right to intervene in any treatment required, or to give his advice on an intervention or decision made by the medical service. Only the FILA Medical Commission delegate may propose to the officials that the bout be stopped.

In competitions where there is no official doctor, the referee can suspend the bout for a maximum of two minutes in any one match. The officials decide if the wrestlers are acting intentionally or not.

This stoppage can be allowed on one or more times and is valid for both wrestlers. The time-keeper for the mat concerned will announce each 30-second interval.

The referee must invite the two wrestlers to return to the centre of the mat ten seconds before the two minutes are up.

In international competitions where the FILA Medical Commission is not represented, the decision to interrupt the bout will be taken by the FILA delegate or by the FILA nominated referee following consultation with the competition doctor and the injured wrestler's team doctor.

In all cases, the doctor making the decision to prohibit the wrestler from continuing the bout shall be of a nationality other than that of the wrestler in question, and the doctor must not be involved in the weight class concerned. (See health regulations.)

The wrestler who deliberately stops the bout without being injured or bleeding, automatically loses 1 point to his opponent.

Article 12 Doping

In applying the provisions of the FILA Constitution, and in order to combat the possibility of drug use, which is formally prohibited, FILA reserves the right to require that wrestlers undergo examinations or tests in all competitions it supervises.

This provision must be applied at Continental and World Championships, according to FILA Regulations, and at the Olympic and Continental Games, according to IOC Rules. In no case may competitors or officers oppose this verification without incurring immediate elimination and the penalties imposed for doping.

The FILA Medical Commission will decide the time, the number or frequency of these examinations, which will be carried out by any means it deems useful.

Suitable samples will be taken by a doctor certified by FILA, in the presence of an officer for the wrestler to be tested.

Where sampling is not carried out under the conditions set out above, the results obtained shall be considered void. (see Doping Regulations)

The setting up and financial implications of the anti-doping controls are paid for by the host country and the National Federations.

The FILA, being subject to the convention fighting drug use signed with the IOC and applied by the World Anti-Doping Agency (WADA), all its Regulations, procedures and sanctions are applicable by the FILA.

The appeal body in the event of a doping sanction made by the FILA Bureau against a wrestler is the Court of Arbitration for Sport (CAS) in Lausanne (Switzerland).

Ranking in the event of doping

If the 1st or 2nd ranked wrestler is disqualified for doping, the bronze medallist who lost by elimination goes up in the ranking.

The 3-4 final loser in the same group will receive the bronze medal. For the rest of the ranking, the other wrestlers will go up according to the ranking system.

CHAPTER 3 - OFFICIALS

Article 13 Composition

In all competitions, the officials for each bout shall consist of the following:

- 1 mat chairman
- 1 referee
- 1 judge

ie: three officials qualified or designated by the Regulations for international judges and referees.

Replacement of an official during a bout is strictly prohibited, except in the case of a serious illness that is medically confirmed.

In no case may two officials be of the same nationality.

Furthermore, it is strictly forbidden for an official to officiate in bouts involving compatriot wrestlers.

Article 14 General duties

- a) Officials shall perform all the duties set forth in the Regulations governing wrestling competitions and in any special provisions which might be established for the organisation of particular competitions.

It is the duty of officials to follow each bout very carefully and to evaluate the actions of the wrestlers so that the results shown on the judge's score sheet accurately reflect the specific nature of said bout.

- b) The mat chairman, referee and judge shall evaluate the holds individually in order to arrive at a final decision. The referee and judge must work together under the direction of the mat chairman, who co-ordinates the work of the officials.
- c) It is the duty of the officials to assume all of the functions of refereeing and judging, to award points and to impose the penalties stipulated in the Rules.
- d) The score sheets of the judge and mat chairman are used to tally all the holds executed by the two opponents. The points, cautions (0) must be recorded with the greatest accuracy, in the order corresponding to the various phases of the bout. These score sheets must be signed by the judge and mat chairman, respectively.
- e) If a bout does not end in a "fall", the decision shall be made by the mat chairman. It shall be based on an evaluation of all the actions of each competitor, recorded from beginning to end on the judge's and mat chairman's score sheets.

- k) All the points awarded by the judge must be announced to the public as soon as they are determined, either by means of bats or by an electric scoreboard.
- g) Officials are required to use the basic FILA vocabulary that is appropriate to their respective roles when conducting the bouts. However, they are forbidden to speak to anybody during the bout, except, of course, amongst themselves when the occasion requires them to do so for consultation and to perform their tasks properly.

Article 15 The referee

- a) The referee is responsible for the orderly conduct of the bout on the mat, which he must direct according to the Rules.
- b) He must command the respect of the contestants and exercise full authority over them so that they immediately obey his orders and instructions. Similarly, he must conduct the bout without tolerating any irregular and untimely outside interventions.
- c) He shall work in close co-operation with the judge and must carry out his duties in supervising the bout while refraining from any impulsive or untimely interference. His whistle shall begin, interrupt and end the bout.
- d) The referee shall order the return of the wrestlers to the mat after they have left it, or the continuation of the bout in the standing or "par terre" position (on the mat), with the approval of the judge, or failing that, with the approval of the mat chairman.
- e) The referee is required to wear a red wristband on his left arm, and a blue wristband on his right arm. He shall indicate with his fingers the points corresponding to the value of a hold after its execution (if it is valid, if it has been executed within the limits of the mat, and if a wrestler has been put in a danger position, etc.), either by raising his right arm if the wrestler in blue scored the points, or by raising his left arm if the wrestler in red scored them.
- f) The referee must never hesitate to:
 - interrupt the bout at exactly the right time, neither too soon nor too late
 - indicate whether a hold executed at the edge of the mat is valid
 - visibly count the five seconds during which the wrestler is held in a bridge position and award the additional point for this situation
 - signal and announce TOUCHE (fall) after seeking the agreement of the judge, or if this is not possible, of the mat chairman. In order to determine whether a wrestler has actually been pinned to the mat by both shoulders at the same time, the referee must say the word 'touche'(fall), raise his hand to secure the agreement of the judge or the mat chairman, strike the mat with his hand and then blow the whistle.

- l) The referee must:
- rapidly and clearly order the position in which wrestling must be resumed, when he sends the wrestlers back to the centre of the mat (their feet must be in the central circle)
 - not stand so close to the wrestlers that he obstructs the view of the judges and the mat chairman, particularly if a fall appears imminent
 - ensure that the wrestlers do not rest during the bout on the pretence of wiping their bodies, blowing their noses, pretending to be injured, etc. In this case, he must stop the bout and ask for a caution (0) to the wrestler at fault and 1 point to his opponent.
 - be able to change his position from one moment to the next, on the mat or around it, and in particular, immediately fall flat onto his stomach to obtain a better view of an imminent fall
 - be able to stimulate a passive wrestler without interrupting the bout, by standing in such a way as to prevent the wrestler from leaving the mat
 - be ready to whistle if the wrestlers come too close to the edge of the mat
- h) The referee is also required to:
- pay special attention to the wrestlers' legs in Greco-Roman Wrestling
 - require the wrestlers to remain on the mat until the result of the bout is announced
 - in all cases where agreement is necessary, first ask the opinion of the judge at the edge of the mat facing the mat chairman
 - proclaim the winner after agreement with the mat chairman
- i) The referee requests penalties for violation of the Rules or for brutality.
- j) The referee, if the mat chairman intervenes, must interrupt the bout and proclaim victory by technical superiority when the wrestlers' scores are 6 points difference. In this situation, he must wait for the action - either an attack or a counter attack - to be complete.
- k) After stopping the match, he must ask the winning wrestler if he wants to carry on the match until the end.
- l) After a 5 points hold, the referee must also ask the winner if he wants to continue the match, but no counter-attack is possible in this situation.

Article 16 The judge

- a) The judge is responsible for all the duties stipulated in the general Rules of wrestling.
- b) He must follow the course of the bout very closely without allowing himself to be distracted in any way; he must award points for each action, and mark them on his score sheet, in agreement with the referee or mat chairman. He must give his opinion in all situations.
- c) Following each action, and on the basis of the referee's indications (which he compares with his own evaluation) or, failing this, on the basis of the mat chairman's indications, he records the number of points awarded to the action in question, and enters the results on a scoreboard placed beside him. This scoreboard must be visible to both the spectators and wrestlers.
- d) The judge verifies and signals the fall (TOUCHE) to the referee
- e) If, during the bout, the judge notices something that he feels he should bring to the referee's attention because the latter was not able to see it or did not notice it (a fall, illegal hold, passive position, etc.), the judge is obliged to do so by raising the bat of the same colour as the singlet of the wrestler in question, even if the referee has not asked for his opinion.

In all circumstances, the judge must call the referee's attention to anything that seems to him abnormal or irregular in the course of the bout or in the conduct of the wrestlers.

- f) The judge must, moreover, sign the score sheet handed to him upon receipt, and at the end of the bout, must clearly record on the score sheet the result of the bout by distinctly crossing out the name of the loser and writing in the name of the winner.
- g) The decisions of the referee and judge are valid and enforceable without the intervention of the mat chairman, if they are in agreement - except for proclamation of victory by technical superiority, in which case the mat chairman is required to give his opinion.
- h) The judge's score sheet must accurately indicate the time at which a bout ends in the case of victory by a fall, technical superiority, withdrawal, etc.
- i) To make it easier for the judge to supervise the bout, particularly in a delicate position, he is authorised to change positions, but only along the edge of the mat over which he has control.
- j) He must also indicate, by underlining, points received by either wrestler for executing the gut wrench.
- k) Cautions for fleeing the mat, illegal holds, or brutality will be noted by an 'O' in the column of the wrestler at fault.

- l) Each time there is a clinch situation, he must indicate by a "K" in the column corresponding to the wrestler who had the clinch last and circle the number of points attributed.

Article 17 The mat chairman

- a) The mat chairman, whose functions are very important, shall assume all the duties provided for in the Rules of wrestling.
- b) He shall co-ordinate the work of the referee and the judge.
- c) He shall order the clinch when the game ends 0-0.
- d) He is obliged to follow the course of the bouts very carefully, without allowing himself to be distracted in any way, and to evaluate the behaviour and action of the other officials according to the Rules.
- e) In the event of any disagreement between the referee and judge, his task is to settle the issue in order to determine the result, the number of points and the falls.
- f) In no case may the mat chairman be the first to give an opinion. He must wait for the opinion of the referee and judge. He is not entitled to influence the decision.
- g) He has the right, in the case of a flagrant violation, to interrupt the bout and to ask for the reasons motivating the decisions made by the referee and judge. After consultation with the referee and judge, he may immediately rectify the decision if the majority of votes are in his favour (2 versus 1) or apply the procedure outlined in article 18.

In general, the mat chairman must be able to apply his technical and special skills as provided for in the relevant chapter of the Regulations for international judges and referees.

Article 18 The Person responsible for refereeing

In all Olympic Games, World Championships, Cups, Championships, Continental Cups and Games and Regional Games, two members of the Refereeing Department will be nominated to supervise all refereeing matters.

During a bout, if the mat chairman notes a serious error on the part of the judge and the referee, and he does not agree with them, he must interrupt the bout. With the agreement of the judge or referee if they accept their errors, he must review the video session and make the decision exactly. On the contrary, the decision cannot be modified.

Article 19 Decision and vote

- a) The referee shall indicate his decision by raising his arm and clearly showing the points with his fingers. If the referee and judge agree, the decision is announced.
- b) The mat chairman is not entitled to influence or change a decision if the referee and judge are in agreement apart from the situation outlined in article 18.
- c) If a vote is taken, the judge and mat chairman must indicate their votes using bats or an electric score board.

There are 11 bats, painted different colours: blue, red and white, as follows:

- one white
- five red, four of which are numbered 1, 2, 3, 5 to indicate the points and one of which is an unmarked bat intended for cautions and to attract attention to the wrestler concerned
- five blue bats, four of which are numbered as the red bats, with one bat unmarked

They must be kept within easy reach of those who are to use them. Under no circumstances may the judge abstain from voting. He must express his decision clearly, leaving no room for ambiguity.

Where there is disagreement, the mat chairman makes the decision. This decision, in which he must decide between the opposing opinions of the referee and judge, obliges the mat chairman to vote in all cases for one or the other of the views given.

- d) If the period lasts until the end of the allotted time, the mat chairman's score sheet will be taken into consideration when designating the winner. The public scoreboard must conform with the mat chairman's score sheet at all times during the bout.

If there is a difference of one or more points between the judge's and mat chairman's score sheets, only the score on the mat chairman's score sheet will be considered.

Article 20 Decision table

Assignment of points

When observing a wrestling action, the referee and judge award the points, cautions, indicated below which, in each of the cases put forward, provides the following result: (R = red wrestler; B = blue wrestler; O = zero points)

Position of the official

Referee	Judge	Mat chairman	Official result	Observations
1R	1R	-	1R	In these examples the judge and referee being in agreement, the mat chairman does not intervene except for serious fault
2B	2B	-	2B	
3R	3R	-	3R	
5R	5R	-	5R	

Referee	Judge	Mat chairman	Official result	Observations
1R	0	0	0	In these examples the judge and the referee being in disagreement, the mat chairman intervenes and the principle of majority applies
1B	1R	1R	1R	
2R	1R	2R	2R	
2B	0	2B	2B	
3R	2R	2R	2R	
3B	1R	3B	3B	

In the event of any flagrant violation of the Rules, the mat chairman must call for a consultation as mentioned in article 18.

At the end of each game the score starts from zero for the following game.

Article 21 Penalties against the officials

The FILA Bureau, which constitutes the supreme jury, shall have the right to take the following disciplinary measures against the official(s) technically at fault:

- 1) Give the official concerned a caution
- 2) Withdraw the official from the competition
- 3) Demote the official to a lower category
- 4) Order a temporary suspension
- 5) Order a final dismissal

Article 22 Dress

The refereeing body: referees, judges and mat chairmen must be dressed in the following manner when exercising their function:

- classic navy jacket with FILA logo
- grey trousers (no turn-ups) with a black belt
- long or short sleeved light blue shirt with the FILA logo on the left chest
- yellow tie with the FILA logo
- black socks
- black plimsolls
- The refereeing body may not wear the name of a sponsor. However, the number on his jacket may include the name of the FILA sponsor.

CHAPTER 4 - COMPETITION PROCEDURE

Article 23 Weigh-in

The final list of contestants must be submitted to the organiser by the team manager, without fail, 6 hours before the start of the weigh-in. No changes will be accepted after this time.

The weigh-in for each category always takes place on the day before the beginning of the competition concerned and lasts 30 minutes.

No wrestler may be accepted at the weigh-in if he has not undergone a medical examination within the time period stipulated in the Regulations governing the competition in question. Medical examinations are always performed one (1) hour before the weigh-in.

Wrestlers must show their licence and passport.

The contestants will be weighed with their singlet but without their shoes after having been examined by qualified physicians who are obliged to eliminate any wrestler who presents any danger of contagious disease.

No weight tolerance will be allowed for the singlet.

Contestants must be in perfect physical condition, with their fingernails cut very short.

Throughout the entire weigh-in period, wrestlers have the right, each in turn, to get on the scale as many times as they wish.

For all competitions, a weigh-in by weight category shall only take place.

Referees responsible for the weigh-in must check that all the wrestlers fulfil all the requirements of Article 8 - Dress and to inform any wrestler of the risk he runs if he presents himself on the mat in incorrect dress. Referees will refuse to weigh a wrestler who is not dressed correctly.

Article 24 Drawing of lots

Participants shall be paired off for each round according to the numerical order determined by the drawing of lots during the weigh-in, before the competition begins.

The drawing of lots must be conducted in public. Numbered tokens corresponding to the number of wrestlers who underwent a medical examination must be enclosed in an urn, a bag or any other similar object. If a different system is used, it must be clear.

The wrestler shall be weighed, and, as he leaves the scales, shall draw his number, on the basis of which he shall be paired off.

This number must be immediately entered on a notice board visible to the public, as well as on the starting and weigh-in list.

Important: When the person responsible for the weigh-in and drawing of lots observes an error in the regulation procedure as outlined above, the drawing of lots for the category in question is to be cancelled. Drawing of lots for this category will then be repeated with the agreement of the technical delegate.

Article 25 Initial classification list

If one or more wrestlers do not attend the weigh-in or are too heavy, after the weigh-in, wrestlers are regrouped in a precise order of classification from the lowest to the highest number.

No. 1	E	No. 7	J	Wrestlers are therefore regrouped by numerical order.
No. 2	H	No. 8	L	
No. 3	B	No. 9	I	
No. 4	A	No. 10	G	
No. 5	D	No. 11	K	
No. 6	C	No. 12	F	

Article 26 Pairing off

Wrestlers shall be paired off in the order of the numbers they drew. A document establishing the correct procedure and time schedule of the bouts must be drawn up, and it must provide all the relevant information concerning the manner in which the competition is to be conducted.

The pairing for each round, as well as the results, are recorded on a board for use by the competitors, who must be able to consult it at all times.
See enclosed table.

Article 27 Elimination from the competition

- The loser is eliminated and ranked according to the classification points marked, except wrestlers who lost against one of the finalists as they take part in the repêchage for the 3rd or 5th places.
- A wrestler who, without medical advice and without notifying the official Secretariat, does not present himself to his opponent when his name is called is disqualified and not placed. His opponent(s) will win the match.
- If a wrestler commits an obvious offence against fair play within the spirit and concept of total and universal wrestling enunciated by FILA, and openly cheats, commits a serious error or engages in brutality, he will be disqualified immediately from the competition and eliminated by a unanimous decision of the officiating team. In this situation, he will not be placed.
- If two wrestlers are disqualified for brutality during the same match, they will be eliminated as above. The wrestler who must be paired with one of these wrestlers, will win the match. The pairing for the following round will not be modified.

- If this qualification perturbs the ranking in a final match, the following wrestlers will move up the table to establish the final classification.
- if the 2 finalists are disqualified, then it will be necessary to make the bout between the two 3rd.

Article 28 Awards ceremony

The first four wrestlers in each weight category shall take part in the awards ceremony, and shall receive a medal and a diploma, according to their ranking.

1st GOLD

2nd SILVER

There will be 2 BRONZE (two 3rd)

At the World Championships, the winner will receive the World Championship Belt. (See Rules governing distinctions and awards).

The wrestlers who are placed 5th to 10th will receive a diploma.

Awards ceremonies take place immediately after the final match of the category concerned.

Article 29 Classification by team during individual competitions

The team classification is determined by the first 10 wrestlers who are classified at the competition.

Place in the weight category	Points	Place in the weight category	Points
1 st	10	7 th	4
2 nd	9	8 th	3
3 rd – 3 rd	8	9 th	2
5 th – 5 th	6	10 th	1

The application of the above-mentioned table remains invariable, whatever the number of wrestlers in each category.

In the event of equal classification of several teams, the team having obtained the most first places is placed first, etc.

Article 30 Classification during team competitions

General principle

A team comprises seven wrestlers, one wrestler for each weight category, with a minimum of six wrestlers per team.

Each team is allowed to weigh-in nine wrestlers.

Each meet comprises two parts (home and away) with a pause of 10 - 15 minutes between each session.

At the end of the second of these sessions, the classification points achieved by each wrestler are totalised and the team with the most classification points is declared the winner.

Each team may change the wrestlers for the second part of the session, as long as they were weighed-in.

If a competition involves only two teams:

The result is determined by adding up the classification points attributed to each wrestler at the end of a match as described in article 46 (5-0/4-0/4-1/3-0/3-1).

The team with the highest number of points is the winner.

If the two teams have an equal number of classification points, the winner will be determined by assessing the following:

- 1) the most victories by fall, default, forfeit etc (5-0)
- 2) the most match victories by technical superiority
- 3) the most period victories by superiority
- 4) the most technical points obtained in all the competition
- 5) the fewest technical points given in all the competition.

If a competition involves more than two teams, the result of each bout is also determined by adding the classification points awarded to each wrestler at the end of a bout.

If two teams have an equal number of classification points, a winner will not be decided according to the quality of the victories, but the teams will be considered to be tied.

The final classification of teams is made by awarding points to each team at the end of each bout.

- the winning team receives two points
- the losing team receives no points
- in case of an equal number of points, both teams receive one point

If, at the end of all competition's matches, two or more teams have the same number of points, they will be placed by adding the classification points accumulated during all the competition, and the team which has the most classification points will be the winner.

In case of an equal number of points, the result of the tournament will determine the winner.

CHAPTER 5 - THE BOUT

Article 31 Duration of the bouts

For all the competitions on the timing boards, the timing will start from 0 to 2 minutes. A light of the same colour as the wrestler concerned must indicate the winner of each period.

The duration of the bouts is set as follows:

For schoolboys and cadets:	three periods of one minute thirty
For juniors and seniors:	three periods of two minutes

At the end of each period, a wrestler is declared the winner. The wrestler winning two periods, is declared the match winner. If the victory can be proclaimed after two periods, the third period is withdrawn.

The fall stops automatically the match whatever the period. In the exceptional case where the period ends 0-0, a clinch will be ordered at the end of the regular time. The clinch lasts maximum 30 seconds.

Article 32 Call

The contestants are called in a loud and clear voice to present themselves on the mat. A contestant cannot be called to compete in a new bout until he has had a rest period of 15 minutes from the time his preceding bout ended.

However, a delay is granted to any wrestler who does not reply to the first request in the following manner:

- The competitors must be called three times at 30-second intervals. If the wrestler does not come forward after the third call, he will be disqualified and will not be placed.
- His opponent will win the bout by default.
- These calls are made in both French and English.

Article 33 Presentation of wrestlers

The following ceremony takes place for each weight category in the finals:

- The finalists for first and second places are presented on the mat with their coaches. The speaker announces their achievements. The mat chairman, referee and judge are also presented with the finalists.

Article 34 Start

Before the bout begins, each opponent answers when his name is called and takes his place at the corner of the mat assigned to him. The corner is the same colour as the singlet he has been assigned to wear.

The referee, standing in the central circle in the middle of the mat, calls the two wrestlers to his side. He then shakes hands with them and examines their dress, checks that they are not covered with any greasy or sticky substance, verifies that they are not perspiring, verifies that their hands are bare and that they have a handkerchief.

The wrestlers greet each other, shake hands and, when the referee blows his whistle, they start the bout.

Article 35 Interrupting the bout

- a) If a contestant finds himself forced to interrupt the period because of an injury or because of any other acceptable incident beyond his control, the referee may stop the wrestling according to article 11 of these Rules.

During such an interruption, the wrestler(s) must stand in their corner. They can cover their shoulders with a towel or their dressing gown and receive advice from their coach.

- b) If a bout cannot be resumed for medical reasons, the decision is made by the competition doctor in charge, who informs both the coach of the wrestler involved and the mat chairman; the latter then orders that the bout be stopped.
- c) The mat chairman may order the period to be interrupted in the event of a serious error on the part of the referee. He may also interrupt the period if there has been a serious scoring error by the referee and judge. In these cases, he will request a consultation. If the mat chairman does not have the majority he must apply the procedure in article 18.
- d) Under no circumstances may a contestant take the initiative to interrupt the action himself, by deciding to wrestle in the standing or "par terre" position, or by pulling his opponent back from the edge of the mat to the centre.
- e) If an action must be stopped due to one wrestler deliberately injuring his opponent, the wrestler at fault will be disqualified and the injured wrestler will be declared the winner.

Article 36 End of the bout

The bout ends either, when a fall, a disqualification, or by injury of one of the opponents are declared.

A period ends either by technical superiority (six points, article 48), or after the execution of a «grand amplitude» 5 points hold whatsoever the score, or after the execution of two holds of 3 points whatsoever the score, or in case of a clinch where the wrestler wins one point or more before 30 seconds, or upon expiration of the wrestling allowed, signalled by the sound of the gong and the referee's whistle.

When a wrestler executes a 5 points hold within the regular time, the referee must wait for the possible fall. If his opponent overcomes, the referee must whistle immediately. He must then ask the winner if he wants to continue the bout. On the contrary, he shall be declared the winner of the match or the bout. The same rule applies to the second hold of 3 points.

To win a match by technical superiority, the winner shall win two periods by technical superiority (twice 6 points difference) or 2 periods with 5 points or 1 point each hold.

In case of technical superiority the referee shall always ask the wrestler if he wants to continue the bout.

This procedure is not applicable in final bouts for 1-2, 3-4.

The wrestler winning a bout by superiority, can decide to continue the bout to try for the pin and to run the risk to lose the bout.

If the referee has not heard the gong, the mat chairman must intervene and stop the bout by throwing a soft object on the mat, in order to attract the referee's attention.

Any action begun at the time when the gong sounds is not recognised and no action performed between the sounds of the gong and the referee's whistle is valid.

When the bout has ended, the referee stands in the centre of the mat facing the officials' table. The wrestlers shake hands, stand on either side of the referee and await the decision. They are forbidden to lower the shoulder straps of their singlets before leaving the competition hall.

Immediately after the decision is announced, the wrestlers shake hands with the referee.

Each wrestler must then shake hands with his opponent's coach. If the above provisions are not observed, the wrestler at fault will be penalised in accordance with the Disciplinary Regulations.

Article 37 Stopping and continuing the bout

General Rules

In all cases, when the wrestling has been stopped in standing or "par terre" position, it will recommence standing.

Wrestling must be stopped and resumed at the centre of the mat in the standing position if:

- a) one foot touches the protection area
- b) the wrestlers in a hold go into the zone with three or four feet without executing the hold and stay there
- c) in any cases if the wrestler leaves the protection zone.

In the exceptional case if an attacked wrestler takes an illegal action in the "par terre" position, he will receive a caution and 1 or 2 points will be attributed to his opponent. The bout resumes "par terre".

Article 38 Types of victories

A bout may be won by:

- a) a "fall"
- b) by injury, withdrawal, default, disqualification of the opponent. At the end of each period, the winner shall be declared. The wrestler who wins two periods is

declared the winner of the match. If the victory can be declared after two periods, the third period is eliminated.

- c) by technical superiority
- d) by points (winning two periods by 1 to 5 points difference)

If the wrestler executes a «grande amplitude» 5 points hold, he shall be declared the winner of the period whatsoever the score.

If the wrestler executes 2 holds of 3 points in the period, he shall be declared the winner of the period whatsoever the score.

In case of a tie by points 1-1, 2-2, 3-3 etc. and when the criteria of holds and cautions are the same, the winner shall be declared not by the first, but by the last point obtained in order to stimulate the whole game.

If there is one or more cautions, the wrestler who has the fewest cautions, shall be declared the winner. If the period ends 0-0, the winner of the period shall be the wrestler who wins one or more points during the ordered clinch in maximum 30 seconds.

For cautions, all the periods will be considered. A wrestler receiving 3 cautions is disqualified

Article 39 Extra time

If at the end of the regular time of a period, the two wrestlers attain 0-0, the referee will stop the bout and order that the bout be resumed in a clinch position (article 52) in maximum 30 seconds.

Article 40 The coach

The coach may remain at the foot of the platform or at least two metres from the edge of the mat during the bout.

Except for the assistance he is authorised to give to a doctor who is providing medical attention to his wrestler, the coach is strictly forbidden to influence decisions or to insult the referee or judge. He may only speak to the wrestler.

If these restrictions are not observed, the referee is obliged to ask the mat chairman to present the coach with a 'Yellow' card (caution); if he persists, the mat chairman will present him with a 'Red' card (elimination).

The mat chairman may also present the YELLOW or RED card on his own initiative.

As soon as the red card is given, the mat chairman reports to the competition director and the coach shall be eliminated from the competition and may no longer continue his duties. However, the wrestling team involved shall have the right to obtain the services of another coach.

The coach does not have the right to give water or any other substance during the pause or during the match.

CHAPTER 6 - POINTS FOR ACTIONS AND HOLDS

Article 41 Evaluation of the importance of the action or hold

In order to remove simulation during bouts, when a wrestler tries unsuccessfully to execute a hold and finds himself underneath in a "par terre" position without a move by his opponent, the wrestler above will not be awarded a technical point. Wrestling continues in a "par terre" position without the referee stopping the bout.

However, if, during a hold, the defending wrestler executes a counterattack and is able to bring his opponent to the ground, he will be awarded the point(s) that correspond to the action.

If the attacking wrestler executes a hold on his own bridge, holds this position for a certain amount of time, and then completes his action by placing his opponent in the bridge position as well, he will not be penalised. Only the attacking wrestler will be awarded the points, as he will have completed the action in a hold that involved risks.

However, if the offensive wrestler is blocked under control in the bridge position or by a counteraction by his opponent, it is clear that points will be awarded to the latter wrestler.

Furthermore, the wrestler on whom a hold was initiated may only be awarded points if, by his own action, he has:

- a) brought the offensive wrestler to the ground
- b) conducted the action on a continuous basis
- c) succeeded in controlling the offensive wrestler by blocking him in a bridge position, that is, in a position considered completed
- d) The referee must wait for the end of each situation prior to awarding the point values earned by each wrestler.
- e) In cases where the wrestlers' actions lead them to change from one position to another, the points for all the actions are awarded according to their value.
- f) The instantaneous fall does not exist (article 47). If the wrestler falls instantly from a standing position following a move by his opponent, the attacker receives three points. If the wrestler falls instantly during his own move, his opponent receives two points. When wrestling in the "par terre" position when the wrestler is in the situation of instant fall, his opponent receives two points.
- g) Rolling from one shoulder to the other using the elbows in the bridge position, and vice-versa, is considered to be only one action.
- h) A hold must not be considered to be a new action until the competitors return to the initial position.
- i) The referee will indicate the points. If the judge agrees, he will raise the bat bearing the colour and value in question (1,2,3 or 5 points). In the event of any

disagreement between the referee and judge, the mat chairman must make a decision in favour of one or the other of the wrestlers; he is not allowed to give a different opinion.

- j) In the event of a fall that occurs at the end of regulation time, only the sound of the gong (and not the referee's whistle) is valid.
- k) At the end of the bout, any hold is valid if it was completed before the gong sounded. In no event may a hold finished after the sound of the gong be counted.

Article 42 Danger position

A wrestler shall be considered in the 'danger position' when the line of his back (or the line of his shoulders) vertically or in parallel with the mat, forms an angle of less than 90 degrees to the said mat and when he resists with the upper part of his body to avoid a 'fall'. (See definition of 'fall').

The 'danger position' occurs when:

- a) the defending wrestler assumes the bridge position to avoid being pinned
- b) the defending wrestler, with his back toward the mat, supports himself on one or both elbows to avoid having his shoulders forced onto the mat
- c) the wrestler has one shoulder in contact with the mat and at the same time exceeds the 90 degree vertical line with the other shoulder (acute angle)
- d) the wrestler finds himself in the 'instantaneous fall' position, that is, when he is on both shoulders for less than one second
- 45) the wrestler rolls over onto his shoulders

The 'danger position' no longer exists when the wrestler exceeds the 90 degree vertical line with his chest and stomach facing the mat.

If the mat and the competitor's back form a 90 degree angle only, this cannot yet be considered a 'danger position' (the neutral point).

Article 43 Recording the points

The judge marks the points obtained for the actions and holds executed by the wrestlers on a special sheet.

He notes them down as each action is performed during the bout.

In order to have uniform scoring, the action bringing about a fall is to be noted on the score sheet by a circle.

In order to distinguish other technical points from those awarded for a gut wrench, points given for a gut wrench must be underlined.

The caution for fleeing the mat, fleeing a hold, refusal to start, illegal hold and brutality shall be noted by (0).

After each caution (0) the opponent will automatically receive one or two technical points, depending on the gravity of the infraction.

The wrestler who can carry out the hold will be marked with "k" and the point(s) encircled.

Article 44 Grand amplitude throw

Any action or hold by a wrestler in the standing position is deemed to be a 'grand amplitude' throw when:

- it causes his opponent to lose all contact with the ground, controls him, makes him describe a broadly sweeping curve in the air, and brings him to the ground in a direct and immediate danger position
- 45) in the "par terre" position, any complete lift from the ground executed by the attacking wrestler, whether the attacked wrestler lands belly down (three points) or in a danger position (five points), is also considered a grand amplitude throw.

N.B. If the wrestler executing a grand amplitude hold himself touches the mat with both shoulders, he receives three or five points and his opponent receives two points, due to the instantaneous fall in the execution of the throw.

Article 45 Value assigned to actions and holds

1 point:

- to the wrestler who brings his opponent to the ground by passing behind him, and while in this position holding him down with control (three points of contact: two arms and one knee or two knees and one arm)
- to the wrestler who applies a correct hold while standing on the mat or in the "par terre" position but who does not place his opponent in danger
- to the wrestler who overcomes, holds and controls his opponent by passing behind him
- to the wrestler who blocks his opponent on one or two outstretched arms, his back facing the mat
- to the wrestler who is prevented from completing a hold because his opponent is maintaining an irregular hold, but who finally succeeds in completing the hold
- to the attacking wrestler whose opponent flees the hold, the mat, refuses to start, commits illegal actions or acts of brutality.
- to the wrestler who holds his opponent in a position of danger for five seconds or longer
- to the wrestler whose opponent goes in the protection zone with one foot
- to the wrestler whose opponent regularly refuses to take a clinch
- all the stops of bout by injury without bleeding are penalised by 1 point to the opponent.

2 points:

- to the wrestler who applies a correct hold while wrestling in the "par terre" position and places his opponent in a position of danger or in an instantaneous fall position
- to the attacking wrestler whose opponent rolls onto his shoulders
- to the attacking wrestler whose opponent flees the hold by jumping off the mat in a position of danger
- to the attacking wrestler whose opponent engages in an illegal hold which prevents him from completing a hold or a fall he had initiated
- to the defending wrestler if the attacking wrestler goes into the instantaneous fall position or rolls onto his shoulders in executing a hold
- to the wrestler who blocks his opponent in the execution of a hold from the standing position, in a position of danger

3 points:

- to the wrestler performing a hold in a standing position, which brings his opponent into a danger position by direct projection over a short amplitude
- for any hold executed by raising a wrestler from the ground, over a short amplitude, even if one or both of the attacking wrestler's knees are on the ground,
- to the wrestler who executes a grande amplitude hold which does not place the opponent in a direct and immediate danger position

NB. If, in performing a hold, the defending wrestler maintains contact with the mat with one of his hands, but is immediately placed in a danger position, the attacking wrestler will receive three points.

5 points:

- all grande amplitude throws executed in a standing position which bring the defending wrestler to a direct and immediate danger position
- the hold executed by a wrestler in the "par terre" position who completely lifts his opponent off the ground with the execution of a grande amplitude throw which projects the opponent into a direct and immediate danger position

CHAPTER 7 - CLASSIFICATION POINTS AWARDED **AFTER A BOUT**

Article 46 Classification points

Principle

The classification points awarded to a wrestler shall determine his final classification.

Classification points at the end of a bout

5 points for the winner and 0 for the loser:

- victory by fall (with or without technical point for the loser)
- injury
- withdrawal
- default
- disqualification
- 3 cautions error against the rules

4 points for the winner and 0 for the loser:

- victory by technical superiority , with the loser scoring no technical points

4 points for the winner and 1 for the loser:

- victory by technical superiority (6 points difference during two periods) with loser scoring technical points

3 points for the winner and 0 point for the loser:

- when out of three periods, the wrestler wins two periods of 1 to 5 points and the loser scoring no point

3 points for the winner and 1 point for the loser :

- when during two periods the bout ends by a victory by points during regular time or by a clinch and the loser scoring one or several technical points.

0 point for the red wrestler and 0 point for the blue wrestler

- in case both wrestlers have been disqualified due to infraction to the rules.

Article 47 The fall

When the defensive wrestler is held by his opponent with his two shoulders against the mat for a sufficient time to allow the referee to observe the total control of the fall, the resulting manoeuvre is considered to be a fall. For a fall at the edge of the mat to be recognised, the competitor's shoulders must be completely in the red zone and the head must not touch the protection area.

A fall in the protection area is not valid.

If the wrestler is pinned on both shoulders as a consequence of a rule infringement or an illegal hold for which he is responsible, the fall will be considered valid for his opponent.

The fall observed by the referee will be valid if the judge or mat chairman indicates his agreement. If the referee does not indicate the fall, and if the fall is valid, it may be announced with the consent of the judge and mat chairman.

Consequently, to be observed and recognised, the fall must be clearly maintained. The two shoulders of the wrestler in question must be simultaneously touching the mat during the short period of stoppage specified in the first paragraph, even in the case of a standing rear body lock and lift. In all cases, the referee will strike the mat only after he has obtained confirmation from the judge or, failing this, from the mat chairman. The referee will then blow his whistle in order to end the bout.

Article 48 Technical superiority

Except for the fall, default or disqualification, the bout must be stopped before the end of regular time when there are 6 points difference between the wrestlers.

The bout may not be interrupted to declare the winner by technical superiority until the action is completed (immediate attack or counterattack).

The mat chairman signals the referee when the difference of six points has been attained. The referee shall declare the winner after consulting with members of the officiating team, for a period or for the match (in which the wrestler won two periods by superiority).

CHAPTER 8 – NEGATIVE WRESTLING

Article 49 “Par terre” position during the bout

If one of the wrestlers brings his opponent to the ground during the match, wrestling continues in the “par terre” position and the wrestler underneath may counter his opponent’s efforts, stand up or carry out counter-attacks of his choice.

If a wrestler brings his opponent to the ground and owing to good defensive action by the attacked wrestler is unable to initiate an action, the referee stops the bout after a reasonable period of time and have the wrestlers resume the bout in a standing position.

The attacking wrestler is forbidden to resume the bout by jumping on his opponent. If he does so, the referee must give him a caution and asks the wrestler in a “par terre” position to stand up again.

The wrestler on top has no right to interrupt the bout nor to request that wrestling resume in a standing position.

NB : Ordering of “par terre” position

Initial position of wrestler in “par terre” position before the referee blows his whistle.

The contestant who is ordered into the “par terre” position must fall on his knees, with his hands on the mat, hands and elbows apart and at least 20 cm from his knees. arms must be straight, his feet uncrossed, his thighs must not touch his heels.

Article 50 Red zone

- a) The red zone is provided for the purpose of detecting the passive wrestler; it is also intended to help eliminate systematic wrestling on the edge of the mat and any departures from the wrestling area.
- any hold or action begun on the central wrestling area and ending within that zone are valid including position of danger, counterattack and fall
 - any hold or counter attack begun in the standing position on the central wrestling area of the mat (apart from the red zone) is good, regardless of the place where it finishes (wrestling area, red zone or protection area)
 - however, if it ends in the protection area, the bout is stopped and the wrestlers are returned to the centre of the mat. In the standing position, points will be awarded according to the value of the hold.
 - a fall in the protection area is not valid. The bout must be interrupted and the wrestlers returned in standing position to the centre of the mat because the hold ended off the mat.
- 46) in a case where the attacking wrestler executing the hold arrives in a fall position in the protection zone, the bout shall be stopped and his opponent shall receive two points. The bout shall be resumed in the centre of the mat, in a standing position.

- In the execution of their started holds and actions, and which have begun on the central surface of the mat, the wrestlers can enter the red zone with three or four feet and continue their actions or holds in all directions, provided that nothing interrupt the execution of their hold (pushing, blocking, pulling).
- 47) an action or a hold may not be commenced in a standing position in the red zone, except under the strict condition that the wrestlers engaged in the hold have only two feet in the zone. In this case, the referee will tolerate the situation for a limited period of time, waiting for the hold to be developed.
- if the wrestlers interrupt their action in the red zone and stay there or if without any action they place two, three or four feet there, the referee interrupts the bout and brings the wrestlers back to the centre, the bout resumes in standing position.
- 48) in all cases, in standing position, if one of the attacking wrestler's feet is in the protection area, that is, outside the red zone, the bout shall be interrupted and the rules applied.
- 49) when the defending wrestler's feet is in the protection area, but the attacking wrestler carries out a hold without interruption, the hold is good. If the attacking wrestler does not carry out the hold, the referee interrupts the bout and the rules are applied.
- when the defending wrestler places one of his foot in the red zone, the referee must call 'ZONE' in a loud voice. Upon hearing this word, the wrestlers must endeavour to return towards the centre of the mat without interrupting their action.
 - in wrestling in "par terre" position, any action, hold or counterattack executed from or in the red zone is good, even if it ends in the protection area.
 - the referee and judge will award points for all actions initiated in "par terre" position in the red zone and executed in the protection area. However, the bout will be interrupted and the wrestlers returned to the centre in a standing position.
 - in wrestling in "par terre" position, the attacking wrestler may continue his action if he moves out of the zone while executing the hold, provided that the shoulders and head of his opponent are within the zone. In this case, even four legs may be off the mat.

Article 51 Clinch

General principle

In the exceptional case where the period ends by no technical points (0-0), a clinch will be ordered at the end of the period (after the regular time), all wrestling styles and for all the age categories. The referee will start the draw at random to determine the wrestler who shall begin the clinch. The clinch will last maximum 30 seconds.

Clinch in free style and women wrestling shall be carried out with the opponent's holding the leg by the wrestler who won the toss.

- In principle the clinch lasts 30 seconds in each style. If the winner of the clinch did not execute a hold, he will receive a caution (0) and his opponent one technical point. The wrestler who wins one point will be declared the winner.
- If a wrestler leaves the mat and the refereeing body can determine which wrestler was the first one to put a foot outside the mat, the sanction will be directly applicable, caution (0), one point.
- If both wrestlers leave the clinch in the protection zone with one foot at the same time, the refereeing body shall decide who is at fault and apply the sanction – caution, (0) and 1 point.
- In the clinch situation, the rule about risk does not apply and the wrestler who find himself underneath or dominated loses the points and the match will end.
- If a wrestler carries his opponent outside the mat without the opponent's feet touching the ground, he will receive a caution and one point to the opponent.

Coin toss

When the score is 0-0 at the end of the first period, the wrestler to carry out the clinch is the one chosen by tossing a coin.

Clinch position in Greco-Roman wrestling

If after a period the clinch is ordered, the referee will ask the wrestlers to place themselves in a clinch position chest against chest. The referee must give the start position in the centre of the mat and all four of the wrestler's feet must be in the 1m diameter central circle.

The wrestler who wins the coin toss holds his opponent under his shoulders without grabbing the arm of his opponent after being placed in a chest against chest position in the centre of the mat.

He can execute his action immediately after his hold was carried out whatever the position of his opponent. The hold can be realised on all the part of the body included since under shoulders up to the top of the belt”.

- The referee-judge has to whistle for the start at once when the wrestler who won the coin toss was able to realise the hold..

Clinch position in free style wrestling

In free style, the referee will start the coin toss to determine the wrestler who shall begin the hold. The loser of the toss must place a leg down on the mat, in the centre of the circle. The wrestler who has won the toss, will hold the leg of his opponent with two arms, the referee whistles and both wrestlers can begin wrestling.

The wrestler who won the coin toss can indicate to the referee the leg which his opponent has to put in the middle of the central circle to know the left or right leg.

CHAPTER 9 - PROHIBITIONS AND ILLEGAL HOLDS

Article 52 General prohibitions

Wrestlers are forbidden to:

- pull the hair, ears, genitals, pinch the skin, bite, twist fingers or toes, etc. and generally, to perform actions, gestures or holds with the intention of torturing the opponent or making him suffer to force him to withdraw
- kick, head-butt, strangle, push, apply holds that may endanger the opponent's life or cause a fracture or dislocation of limbs, tread on the feet of the opponent or touch his face between the eyebrows and the line of the mouth
- thrust the elbow or knee into the opponent's abdomen or stomach, carry out any twisting action which is likely to cause suffering, or hold the opponent by his singlet
- cling to or grasp the mat
- talk during the bout
- seize the sole of the opponent's foot (only seizing the upper part of the foot or the heel is permitted)
- agree the match result between themselves

Article 53 Fleeing a hold

Fleeing a hold occurs when the defending wrestler openly refuses contact in order to prevent his opponent from executing or initiating a hold. These situations arise in both the standing and "par terre" positions. They may occur in the central wrestling area or from the central wrestling area to the red zone. Fleeing a hold shall be penalised in the same way as fleeing the mat, that is:

- one caution against the wrestler at fault (0)
- one point to the opponent

On the ground in Greco-Roman Wrestling

When a wrestler is on the ground following an action by his opponent and he then jumps forward to prevent his being caught for a hold, he puts his opponent in the position of committing an illegal hold - holding the thighs of the "escaping" wrestler, will be considered as a fleeing of a hold.

The referee must not allow this situation which is a fleeing the hold offence by the fleeing wrestler. He must therefore be very clear and precise in the manner in which he deals with this offence.

- The first time that the wrestler on the ground jumps forward to avoid being caught by his opponent, the referee must warn aloud "attention, no jump".
- The second time, the referee must request a caution and 1 point for fleeing the hold, stop the match following agreement by the judge and the match chairman, make the wrestlers stand up, signal the offence and restart the match in Standing position.

This method is valid for penalising fleeing the hold when the wrestler jumps forward. However, the defence of moving laterally to avoid a hold is authorised and should not be sanctioned.

The wrestler who is dominated on the ground does not have the right to bend or raise either or both of his legs to prevent a hold being executed.

If a dominated wrestler on the ground uses his legs as a defence, he will receive a caution (O) and his opponent two points.

Standing in Free Style and Greco-Roman Wrestling

The wrestler who refuses contact in Free Style and Greco-Roman wrestling or who gesticulates to simulate contact must be sanctioned as he is cheating and going against the spirit of wrestling.

The referee must give an amicable verbal caution the first time, saying "red contact" or "blue contact". If the wrestler still refuses contact, he will be penalised with a caution and his opponent will receive one point for fleeing the hold. After the referees stops the bout, wrestling resumes in a standing position.

Article 54 Fleeing the mat

When a wrestler flees the mat, from either a standing or "par terre" position, a caution shall immediately be issued against the wrestler at fault.

The following points shall be awarded to the attacking wrestler:

Fleeing the mat

- one point + one caution against the opponent (0)

Fleeing the mat in a position of danger:

- two points + caution against the opponent (0).

All points for fleeing the mat are considered technical points.

Article 55 Illegal holds

The following holds and actions are illegal and strictly prohibited:

- throat hold
- twisting of arms more than 90 degrees
- arm lock applied to the forearm
- holding the head or neck with two hands, as well as all situations and positions of strangulation
- double Nelson, if not executed from the side without the use of the legs on any part of the opponent's body
- bringing the opponent's arm behind his back and at the same time applying pressure to it in a position where the forearm forms an acute angle
- executing a hold by stretching the opponent's spinal column

- chancery hold with one or two hands in any direction whatsoever
- the only holds allowed are with the head and one arm
- in standing holds executed from behind when the opponent is head down (reverse waist hold), the fall must be executed only to the side and never from top to bottom (header)
- in executing a hold, only one arm may be used to hold the opponent's head or neck
- to lift the opponent who is in a bridge position and then to throw him onto the mat (severe impact on the ground); that is, the bridge must be forced down
- breaking the bridge by pushing in the direction of the head
- generally, if the attacking wrestler is found to have violated the Rules during the execution of a hold, the action in question shall be completely void and the wrestler at fault, penalised (caution). If the attacker repeats his violation, he will be punished by a caution. One point will be awarded to his opponent.
- if a defending wrestler, by an illegal action, prevents his opponent from developing his hold, the defending wrestler will be cautioned. His opponent will receive two points.

The duties of the referee towards the competitor committing a violation are as follows:

If the wrestler can carry out the action

- stop the violation
- force the wrestler to release the hold if it is dangerous
- ask for a caution
- give a point
- give the value corresponding to the hold to his opponent
- stop the match
- resume wrestling in the position where it was interrupted

If the wrestler cannot carry out his action

- stop the match and ask for a caution
- give two points to his opponent
- resume wrestling in the position where it was interrupted

Article 56 Prohibited holds for the schoolboy and cadet categories

To protect the health of young wrestlers, the following holds are considered illegal and prohibited for the schoolboy and cadet categories:

- double Nelson from both the front and side
- in Free Style wrestling, a leg hook on the opponent's leg, in addition to the double Nelson

Article 57 Special prohibitions

- In Greco-Roman wrestling, it is forbidden to grasp the opponent below the hips and to squeeze him with the legs. All pushing, pressing or 'lifting' by means of contact with the legs on any part of the body of the opponent is also strictly forbidden.
- In Greco-Roman Wrestling, unlike in Free Style Wrestling, it is necessary to accompany the opponent to the ground and to stay in contact with him in order for a hold to be valid.
- In Free Style Wrestling, a scissor-lock with the feet crossed on the head, neck or body is forbidden

Article 58 Consequences affecting the bout

- The illegal hold of the attacked wrestler shall be stopped by the referee without interrupting the hold if possible. If there is no danger, the referee allows the development of the hold and waits for the result. He then stops the match, gives the points and a caution to the wrestler at fault.
- If the hold begins properly and then becomes illegal, the hold should be evaluated up until the beginning of the infraction, then the match should be stopped and wrestling should be made to continue in a standing position with the attacking wrestler receiving an amicable caution. If the wrestler attacks again with an illegal hold, the referee will stop the match, give a caution (0) to the wrestler at fault, one point to his opponent.

In all cases, in the event of any wilful butting with the head or any other brutality, the wrestler at fault may be eliminated immediately from the bout by a unanimous decision of the officiating team, or disqualified from the competition and placed last with a comment "eliminated for brutality".

CHAPTER 10 - THE PROTEST

Article 59 The protest

No protest may be lodged at the end of a match. Only the result obtained on the mat counts.

If the FILA President or the Refereeing Department note that the refereeing body have abused their power to modify a match result, they can examine the video and, with the agreement of the FILA Bureau, sanction those responsible as laid down in the provisions of the Regulations for International Refereeing Bodies.

Under no circumstances may the result of a match be modified.

CHAPTER 11 - INTERNATIONAL RULES SPECIFIC TO WOMEN'S WRESTLING

Article 60 Age categories and weight categories

The age categories for women's wrestling will be:

SCHOOLGIRLS	14-15 years (from the age of 13 with a medical certificate and parental authorisation)
CADETS	16-17 years (from the age of 15 with a medical certificate and parental authorisation)
JUNIORS	18-20 years (from the age of 17 with a medical certificate and parental authorisation)
SENIORS	20 years and over

Wrestlers who are 17 in the year in the cadet category may compete in the senior category with a medical certificate and parental authorisation.

The weight categories are as follows:

SCHOOLGIRLS	CADETS	JUNIORS	SENIORS
28-30kg	36-38kg	40-44kg	44-48kg
32kg	40kg	48kg	51kg
34kg	43kg	51kg	55kg
37kg	46kg	55kg	59kg
40kg	49kg	59kg	63kg
44kg	52kg	63kg	67kg
48kg	56kg	67kg	67-72kg
52kg	60kg	67-72kg	
57kg	65kg		
57-62kg	65-70kg		

Article 61 Dress

Participants must present themselves for competition as defined in article 8.

In addition:

- the wearing of an under-wired bra is forbidden

- it is forbidden to wear earrings, hair slides, bracelets, rings, or any metal or rigid object, as well as a man's wrestling singlet with a T-shirt underneath
- FILA approved ear protectors are obligatory for all cadet and junior women wrestlers. Senior participants may chose whether to wear them.

Article 62 Weigh-in

Principle

Participants are weighed in the same way as the men as mentioned in article 23 of these Rules.

Article 63 Length of the bout

SCHOOLGIRLS AND CADETS	3 periods of 1 minute 30 seconds
JUNIORS AND SENIORS	3 periods of 2 minutes

The break between the three periods is 30 seconds.

Article 64 General technical rules

All technical Rules in these Rules for men's wrestling apply in women's wrestling.

Article 65 Illegal holds

As well as the general illegal holds established in these Rules for men's wrestling, the following holds are prohibited in women's wrestling :

All double Nelsons in the "par terre" or standing position.

CHAPTER 12 - INTERPRETATION OF WRESTLING RULES

Article 66 Modifications and unforeseen events

These Rules supersede all former editions.

The FILA Executive Bureau is the sole decision-making authority concerning any modifications to the above provisions that are deemed desirable with a view to improving the technical Rules of wrestling.

These Rules have been drawn up bearing in mind all the circulars and information distributed by the FILA.

They contain all the suggestions put forward by the auxiliary bodies and the Bureau which were accepted by the FILA Congress.

These Rules are the only valid document of their type until the following Congress which will be asked to rule on all the possible modifications or interpretations decided by the Executive Bureau.

In the event of a trial, only the French text is valid.

The National Federations must translate this document into their official language.

Every referee at a competition must have copy of these Rules in his language and in one of the FILA's official languages (French or English).

Lausanne, 01.01.2005

CHAPTER 13 – BEACH WRESTLING

REGULATIONS FOR MEN AND WOMEN

Age categories

- 10 to 15 years cadets
- 16 to 20 years juniors
- 21 years and more seniors

Weight categories

The person in charge divides the participants into 2 categories:

- One light category
- 45) One heavy category

There is no weigh-in, the distribution in the categories is carried out according to the corpulence of the participants and in order to reach the quickest possible ideal divisible number .

Kind of competition

- Tournament or championship open to all without any affiliation nor licence
- Tournament or championship reserved for those affiliated to a National Federation

Competition dress

- Trunks for men without any other accessory
- Swimsuit in one piece or two pieces for women without any other accessory

Competition surface

On sand, inside a circle of 6 m diameter

Duration of the matches

One period of maximum three (3) minutes

Competition system

The competition takes place with direct elimination. The losers of the ½ finals are both ranked in the 3rd place

Identification of the men and women wrestlers

After having been distributed by categories, each wrestler receives an ankle band numbered from 1 to ...(different for each category) to be put around the ankle. After each match the loser hands the band to the referee.

Officiating

The person in charge acts as referee and his decisions cannot be questioned.

Kind of victories

“Beach Wrestling” is held only in the standing position. The victory can be obtained in the following manner:

- By fall when a wrestler touches both shoulders on the ground
- By throw when a wrestler has succeeded in having his opponent touch twice during the match a part of his body on the ground. In the action the attacking wrestler can put one or both knees on the ground.
- By leaving the competition area if a wrestler has succeeded in pushing twice one foot of his opponent out of the competition area.
- By adding to a throw a leaving of the competition area.
- By decision of the person in charge when at the end of 3 minutes no action was executed by one wrestler compared with the activity of the other wrestler.

Prohibitions

- Kick or punch
- Attack the face or the hair
- Cover the body with an oily and slippery substance
- Holds that can lead to a dislocation
- Stopping the match for any reasons is forbidden

Classification

One 1st, one 2nd and two 3rd places are declared for each light and heavy category .

The two first of each category must wrestle to determine the winner of the absolute category of the tournament.

1st of the light category against the 1st of the heavy category
2nd of the light category against the 2nd of the heavy category

APPENDIX 1 - BASIC VOCABULARY

Every member of the officiating team must be perfectly familiar with and apply the vocabulary set out below. This vocabulary constitutes the official means of communication between members.

- 1) **SALUT**
The wrestlers must greet each other.
- 2) **START**
The invitation to the wrestlers standing at opposite corners of the mat to step to the centre to be examined and shake hands. After this, they will return to their respective corners and await the referee's whistle calling on them to begin wrestling.
- 3) **CONTACT**
The referee calls upon the wrestler to place both his hands on the back of his opponent, who is underneath on the ground. Wrestlers in the standing position must assume 'body-to-body' contact.
- 4) **OPEN**
The wrestler must alter his position and adopt more open wrestling tactics.
- 5) **DAWAI**
The referee encourages the wrestlers to wrestle more actively.
- 6) **ATTENTION**
The referee warns the passive wrestler before requesting a caution for refusal to assume the correct "par terre" position.
- 7) **ACTION**
The wrestler must execute the hold that he has initiated.
- 8) **HEAD UP**
The wrestler must raise his head. This order is given by the referee in the case of repeated attacks by a wrestler who thrusts his head forward.
- 9) **JAMBE**
The wrestler has committed a leg error (Greco-Roman).
- 10) **POSITION**
Initial position of the wrestlers on the ground (or in ordered contact in Greco-Roman wrestling), before the referee blows his whistle
- 11) **A TERRE**
The bout is resumed in the "par terre" position.
- 12) **PLACE**
By striking the mat with his hand and at the same time pronouncing the word 'place' the referee reminds the wrestlers not to flee the mat.
- 13) **DANGER**
The danger position.
- 14) **FAULT**
An illegal hold or violation of the technical Rules

- 15) **STOP**
This word means the stopping of the bout.
- 16) **ZONE**
This word must be spoken in a loud voice if the wrestlers enter the red zone.
- 17) **CONTINUER**
The bout must be resumed upon this order by the referee. The referee also uses this word to have the wrestling continued if the wrestlers stop due to confusion and look at him as if they are asking for an explanation.
- 18) **TIME OUT**
When one of the wrestlers stops wrestling, intentionally or because of injury or any other reason, the referee will use this expression to ask the timekeeper to stop his stopwatch.
- 19) **CENTRE**
The wrestlers must return to the centre of the mat and continue the bout there.
- 20) **UP**
The bout must be resumed in the standing position.
- 21) **INTERVENTION**
The judge, referee or mat chairman call for intervention.
- 22) **OUT**
A hold applied outside the mat.
- 23) **OK**
The hold is valid (legal, correct). If the judge and mat chairman are sitting in a position that does not allow them to follow closely what is taking place on the opposite side, the referee must raise his arm to indicate whether the hold at the edge of the mat was executed within the boundaries of the mat or outside.
- 24) **NON**
This word is used to indicate that an action is not valid and is consequently void.
- 25) **TOUCHE**
The word used to indicate that the wrestler is beaten by a 'fall.' For a fall, the referee himself says 'tombé', strikes the mat with his hand, and blows his whistle to indicate the end of the bout.
- 26) **DECLARE BATTU**
The decision made subsequent to a defeat by decision of the officiating team.
- 27) **DEFAITE**
The opponent is beaten.
- 28) **DISQUALIFICATION**
The disqualification is announced for unsportsmanlike conduct or brutality.
- 29) **FIN**
The end of the bout.
- 30) **CHRONOMETRE**
The timekeeper must stop or start the stopwatch on this order from the referee.
- 31) **GONG**
The sound of the gong marks the beginning and end of a bout.

- 32) **JURY**
The officiating body (team).
- 33) **ARBITRE**
The official conducting the bout on the mat.
- 34) **JUGE**
The official who assists the referee and awards the points to the wrestlers during the bout. He is also required to note all the actions executed during the bout on his score sheet.
- 35) **CHEF DE TAPIS**
The mat chairman, who is the official responsible for a mat. He is obliged to break a tie vote between the referee and judge in case of a dispute.
- 36) **CONSULTATION**
The mat chairman consults with the referee and judge before announcing a disqualification or decision on any matter on which there has been disagreement.
- 37) **AVERTISSEMENT**
The penalty issued by the referee to a wrestler for violation of the Rules.
- 38) **CLINIC**
The referees' course.
- 39) **PROTEST**
The protest filed as a result of a decision, whatever it may be.
- 40) **DOCTEUR**
The official doctor for the bout.
- 41) **VICTORY**
The referee declares the winner.
- 42) **NO JUMP**
Referee's comment to the wrestler par terre who jumps forward in order to prevent his opponent being able to initiate a hold.
- 43) **CLINCH**
Provision laid down in article 51.
- 44) **SCORESHEET**
Sheet of the match
- 45) **ROUNDSHEET**
Sheet of the round

Lausanne, 01.01.2005